

# COBRA 1.8

The next generation of fog generators

a Look Solutions product

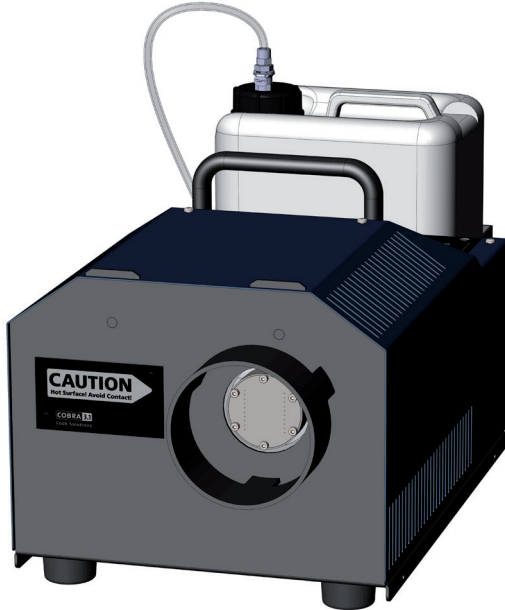

newly developed,  
extremely silent nozzle

constant, steady Output

DMX, Ethernet, RDM

Made in Germany

The **Cobra 1.8** is a powerful fog generator, that sets new Standards concerning noise and handling.

The new Touchscreen makes the handling of the **Cobra 1.8** easy and intuitive.

Operation via Ethernet and RDM-features allow most flexible use.

The machine is supplied with a duct adaptor that also functions as a protection against contact.

## Features

### • New developed, extremely silent nozzle

With its newly developed nozzle the machine works very silent. The noise level at full output is 82.5 dBA (in comparison: the Viper 2.6 with 2600 Watt generates 100.5 dBA at full output).

The nozzle can be unscrewed and cleaned as needed.

### • Two pumps for constant output

The use of two pumps ensures a very constant fog output at any pump level.

Therefore the continuous output up to 30% pump level is regulated from one pump, levels from 31% to 100% are regulated by a second, more powerful pump.

### • New Touchscreen

All adjustments can be made easily and intuitive via the big Touchscreen with simple menu navigation.

### • New control choices

Beside the stand-alone, analogue and DMX 512 control, the machine can also be operated via Ethernet (Artnet and sACN).

### • RDM-capable

The **Cobra 1.8** is equipped with the following RDM-features:

- Status: Ready, Re-heating, Error messages (E-1, E-2 etc)
- DMX-Patch
- Temperature: Heating element, PCB
- Adjusting the Personality
- General Informations about the machine

### • Finest adjustments of the output

Digital technology enables fine adjustments of the pump. In steps of 1% the output can be adjusted from 0 - 100%. Thus, any desired effect - from a tiny fog cloud to the thickest continuous fog - can be produced. This allows an individual adaptation to the dimensions of the room.

### • Adjustable pump characteristic

Depending on the use of the **Cobra 1.8** and the desired effect, the user can choose between four different pump characteristics: Impulse, Extended, Flood and Continuous.

The output and fogging time varies depending on the chosen pump characteristic.

### • Adjustable performance curve

For finest adjustments of the pump from 0% - 30%. In these-pump levels, the performance curve can be regulated 5% up or down, if the same output is needed at several machines or the aging process influences the output. Thus, different fog amounts can be balanced.

### • Internal timer

With the internal timer, the fogging time can be adjusted in seconds, the wait time in minutes and the output in %. Once the timer is activated, the adjusted program will run until the timer is deactivated.

### • Working hour meter

The **Cobra 1.8** is equipped with a working hour meter, that saves heating and fogging durations.

## Liquid

The following Look fog liquids are available for the **Cobra 1.8**:

- Quick-Fog (thick, quick disappearing fog liquid)
- Regular-Fog (thick, long lasting fog liquid)
- Slow-Fog (thick, extremely long lasting fog liquid)

## Specifications

<b>Procedure</b>	Vaporizing fog generator
<b>Power requirement</b>	1800 Watt
<b>Voltage</b>	120 V/60 Hz
<b>Heat-up time</b>	approx. 20 min.
<b>Fluid consumption, measured with Look Regular-Fog</b>	
at max. Output	175 ml/min.
at continuous output	28 ml/min.
<b>Fluid tank capacity</b>	5 Liter
<b>Fog output</b>	adustable in 100 steps of 1%
<b>Output projection</b>	max. 25 m
<b>Fogging time at 100% output</b>	Extended-Mode: approx. 50 sec. Impulse-Mode: approx. 22 sec.
<b>at &lt; 30% output</b>	Continuous output
<b>Control</b>	Manual 0 - 10 V analogue DMX 512 Ethernet (Artnet, sACN) Timer Radio remote (option) XLR-remote (option)
<b>Temperature control</b>	Microprocessor controlled
<b>Overheating protection</b>	Heater block/Thermostat Pump/Thermal switch
<b>Dimensions (L x W x H)</b>	58 x 26.5 x 26 cm
<b>Weight without tank</b>	16 kg

## Dimensions

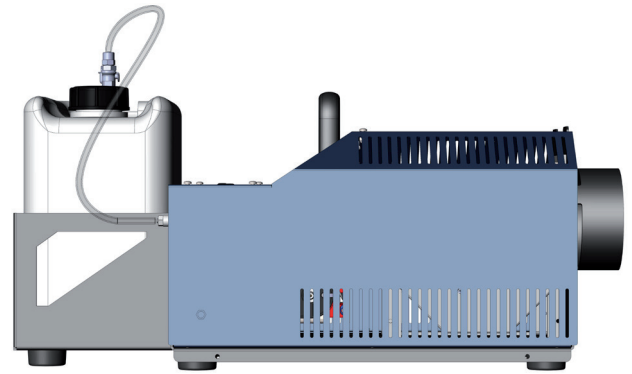

14.5 cm | 37.5 cm | 6 cm

58 cm

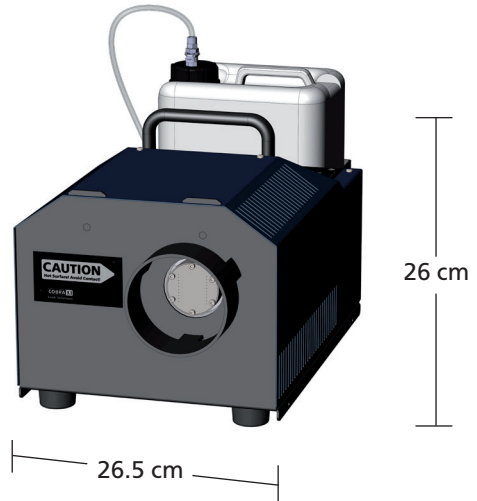

26 cm

26.5 cm

## Advantages

- Extremely silent nozzle
- Two pumps for strong, constant output
- Control via Ethernet, DMX 512, analogue (0 - 10 V) and manual mode
- Internal Timer
- Adjustments via Touchscreen with simple menu
- Several RDM features
- Fog output adjustable from 0 - 100% in steps of 1%
- Adjustable Pump characteristic
- Adjustable Performance curve
- Working hour meter
- Production and Service in Germany

## Accessories (option)

- XLR-remote for analogue control
- Radio remote
- Flightcase

## Service

Based on the strong partnership with the german manufacturer, Look Solutions is able to provide a quick and easy service which guarantees the high quality of all products.